

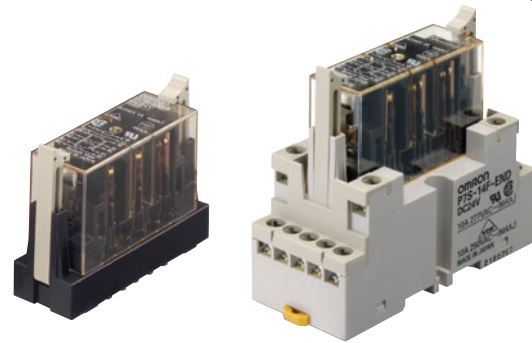

## Relays Conforming to EN Standard

- Relays with forcibly guided contacts (EN50205 Class A, certified by VDE).
- Supports the CE marking of machinery (Machinery Directive).
- Helps avoid hazardous machine status when used as part of an interlocking circuit.
- Track-mounting and Back-mounting Sockets are available.



 Be sure to read the "Safety Precautions" on page 5 and the "Precautions for All Relays with Forcibly Guided Contacts".

## Model Number Structure

### Model Number Legend

G7S- A B

1      2

1. **NO Contact Poles**
  - 4: 4PST-NO
  - 3: 3PST-NO
2. **NC Contact Poles**
  - 2: DPST-NC
  - 3: 3PST-NC

## Ordering Information

### Relays with Forcibly Guided Contacts

Type	Poles	Contact configuration	Rated voltage	Model
Standard	6 poles	4PST-NO, DPST-NC	24 VDC	<b>G7S-4A2B</b>
		3PST-NO, 3PST-NC		<b>G7S-3A3B</b>

### Sockets

Type		Rated voltage	Model
Track-mounting	Common for track mounting and screw mounting	24 VDC	<b>P7S-14F-END</b>
Back-mounting	PCB terminals	---	<b>P7S-14P-E</b>

## Specifications

### Ratings

#### Coil

Rated voltage	Item	Rated current (mA)	Coil resistance ( $\Omega$ )	Must operate voltage (V)	Must release voltage (V)	Max. voltage (V)	Power consumption (W)
24 VDC		30	800	80% max.	10% min.	110%	Approx. 0.8

- Note:**
1. The rated current and coil resistance are measured at a coil temperature of 23°C with tolerances of  $\pm 15\%$ .
  2. Performance characteristics are based on a coil temperature of 23°C.
  3. The maximum voltage is based on an ambient operating temperature of 23°C maximum.

#### Contacts

Item	Load	Resistive load	Inductive load ( $\cos \phi = 0.4, L/R = 7 \text{ ms}$ )
Rated load		240 VAC: 3 A, 24 VDC: 3 A	240 VAC: 3 A, 24 VDC: 1 A
Rated carry current		6 A	
Maximum switching voltage		250 VAC, 24 VDC	
Maximum switching current		6 A	

### Characteristics of Sockets

Model	Continuous current	Dielectric strength	Insulation resistance
P7S-14□	10 A	2,000 VAC for 1 min. between terminals	1,000 M $\Omega$ min. *

**Note:** Use the P7S-14F-END in the ambient humidity range of 35 to 85%.

\* The insulation resistance was measured with a 500-VDC megohmmeter at the same locations as the dielectric strength was measured.

### Characteristics

Contact resistance *1		100 m $\Omega$ max.
Operating time *2		50 ms max.
Release time *2		50 ms max.
Maximum operating frequency	Mechanical	18,000 operations/h
	Rated load	1,800 operations/h
Insulation resistance *3		100 M $\Omega$ min.
Dielectric strength		2,500 VAC, 50/60 Hz for 1 min. (1,500 VAC between contacts of same polarity)
Vibration resistance	Destruction	10 to 55 to 10 Hz, 0.75-mm single amplitude (1.5-mm double amplitude)
	Malfunction	10 to 55 to 10 Hz, 0.375-mm single amplitude (0.75-mm double amplitude)
Shock resistance	Destruction	1,000 m/s <sup>2</sup>
	Malfunction	100 m/s <sup>2</sup>
Durability *4	Mechanical	10,000,000 operations min. (at approx. 18,000 operations/h)
	Electrical	100,000 operations min. (at the rated load and approx. 1,800 operations/h)
Failure rate (P level) (reference value *5)		5 VDC, 1 mA
Ambient operating temperature		-25 to 70°C (with no icing or condensation)
Ambient operating humidity		5% to 85%
Weight		Approx. 65 g

**Note:** The above values are initial values.

\*1. Measurement conditions: 5 VDC, 10 mA, voltage drops.

\*2. Measurement conditions: Rated voltage operation

Ambient operating temperature: 23°C

Contact bounce time is not included.

\*3. The insulation resistance was measured with a 500-VDC megohmmeter at the same locations as the dielectric strength was measured.

\*4. The durability is for an ambient temperature of 15 to 35°C and an ambient humidity of 25% to 75%.

\*5. The failure rate is based on an operating frequency of 60 operations/min.

# Engineering Data

## Durability Curve (Rated Resistive Load)

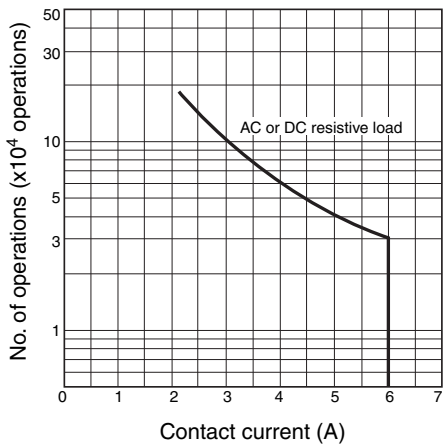

## Dimensions

(Unit: mm)

### Relays with Forcibly Guided Contacts

G7S-4A2B  
G7S-3A3B

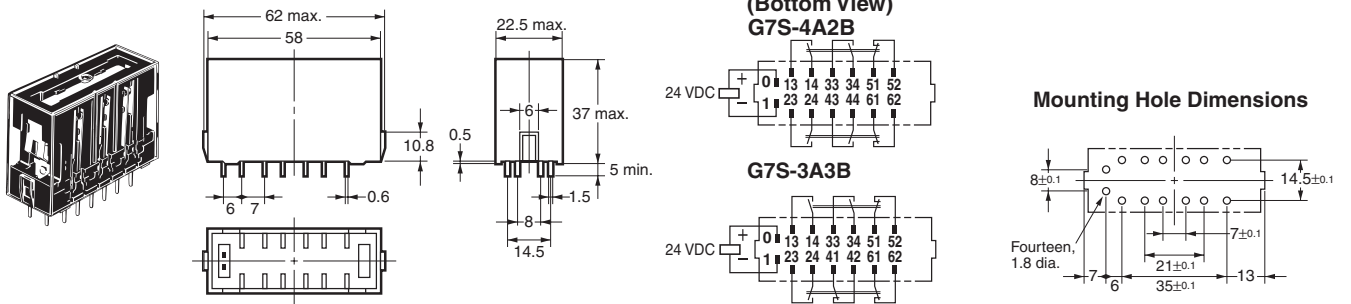

Sockets

Track-mounting Socket

P7S-14F-END

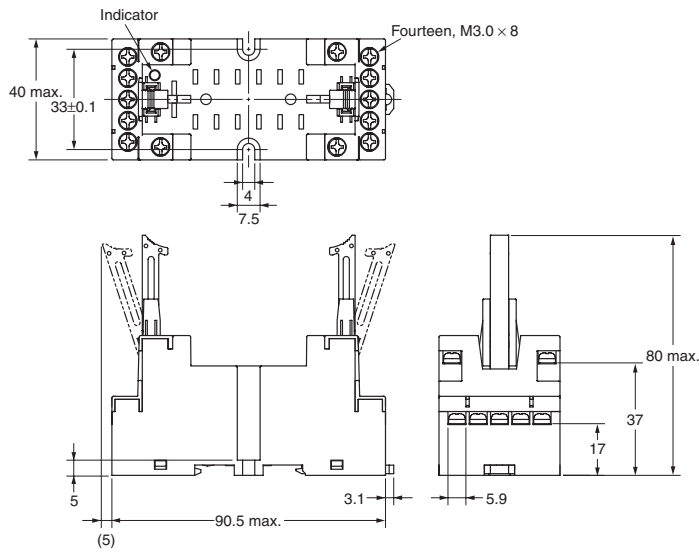
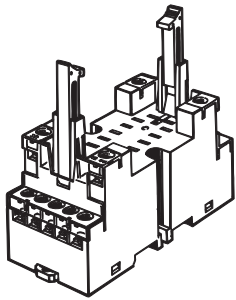

Terminal Arrangement/Internal Connection Diagram (Top View)

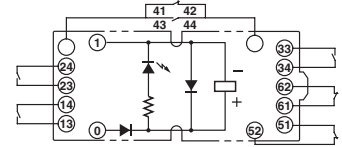

Mounting Hole Dimensions

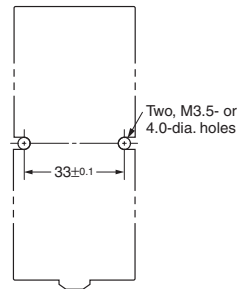

Back-mounting Socket (PCB Terminals)

P7S-14P-E

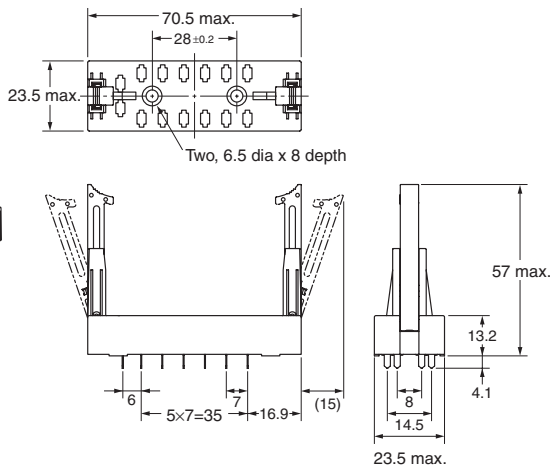
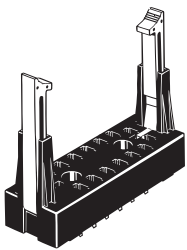

Terminal Arrangement/Internal Connection Diagram (Bottom View) With G7S-4A2B mounted

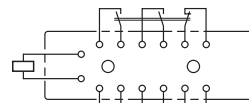

With G7S-3A3B mounted

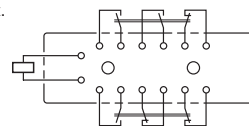

Mounting Hole Dimensions

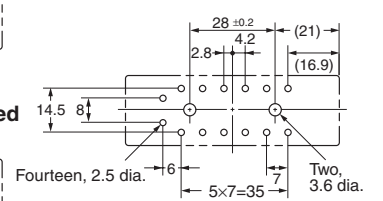

## Certified Standards

---

- EN Standards, VDE Certified  
EN61810-1 (Electromechanical non-specified time all-or-nothing relays)  
EN50205 (Relays with forcibly guided (linked) contacts)
- UL standard UL508 Industrial Control Devices
- CSA standard CSA C22.2 No. 14 Industrial Control Devices

## Forcibly Guided Contacts (from EN50205)

---

If an NO contact becomes welded, all NC contacts will maintain a minimum distance of 0.5 mm when the coil is not energized. Likewise if an NC contact becomes welded, all NO contacts will maintain a minimum distance of 0.5 mm when the coil is energized.

## Safety Precautions

---

Refer to the *“Precautions for All Relays”* and *“Precautions for All Relays with Forcibly Guided Contacts”*.

<b>Precautions for Correct Use</b>
------------------------------------

### Wiring

- Use one of the following wires to connect to the P7S-14F-END.  
Stranded wire: 0.75 to 1.5 mm<sup>2</sup>  
Solid wire: 1.0 to 1.5 mm<sup>2</sup>
- Tighten each screw of the P7S-14F-END to a torque of 0.78 to 0.98 N·m.
- Refer to the internal connections diagram of the G9S Safety Relay Unit for an application example of the G7S.
- Wire the terminals correctly with no mistakes in coil polarity, otherwise the G7S will not operate.

### Cleaning

The G7S is not of enclosed construction. Therefore, do not wash the G7S with water or detergent.

## Read and Understand This Catalog

Please read and understand this catalog before purchasing the products. Please consult your OMRON representative if you have any questions or comments.

## Warranty and Limitations of Liability

### WARRANTY

OMRON's exclusive warranty is that the products are free from defects in materials and workmanship for a period of one year (or other period if specified) from date of sale by OMRON.

OMRON MAKES NO WARRANTY OR REPRESENTATION, EXPRESS OR IMPLIED, REGARDING NON-INFRINGEMENT, MERCHANTABILITY, OR FITNESS FOR PARTICULAR PURPOSE OF THE PRODUCTS. ANY BUYER OR USER ACKNOWLEDGES THAT THE BUYER OR USER ALONE HAS DETERMINED THAT THE PRODUCTS WILL SUITABLY MEET THE REQUIREMENTS OF THEIR INTENDED USE. OMRON DISCLAIMS ALL OTHER WARRANTIES, EXPRESS OR IMPLIED.

### LIMITATIONS OF LIABILITY

OMRON SHALL NOT BE RESPONSIBLE FOR SPECIAL, INDIRECT, OR CONSEQUENTIAL DAMAGES, LOSS OF PROFITS OR COMMERCIAL LOSS IN ANY WAY CONNECTED WITH THE PRODUCTS, WHETHER SUCH CLAIM IS BASED ON CONTRACT, WARRANTY, NEGLIGENCE, OR STRICT LIABILITY.

In no event shall the responsibility of OMRON for any act exceed the individual price of the product on which liability is asserted.

IN NO EVENT SHALL OMRON BE RESPONSIBLE FOR WARRANTY, REPAIR, OR OTHER CLAIMS REGARDING THE PRODUCTS UNLESS OMRON'S ANALYSIS CONFIRMS THAT THE PRODUCTS WERE PROPERLY HANDLED, STORED, INSTALLED, AND MAINTAINED AND NOT SUBJECT TO CONTAMINATION, ABUSE, MISUSE, OR INAPPROPRIATE MODIFICATION OR REPAIR.

## Application Considerations

### SUITABILITY FOR USE

OMRON shall not be responsible for conformity with any standards, codes, or regulations that apply to the combination of products in the customer's application or use of the products.

At the customer's request, OMRON will provide applicable third party certification documents identifying ratings and limitations of use that apply to the products. This information by itself is not sufficient for a complete determination of the suitability of the products in combination with the end product, machine, system, or other application or use.

The following are some examples of applications for which particular attention must be given. This is not intended to be an exhaustive list of all possible uses of the products, nor is it intended to imply that the uses listed may be suitable for the products:

- Outdoor use, uses involving potential chemical contamination or electrical interference, or conditions or uses not described in this catalog.
- Nuclear energy control systems, combustion systems, railroad systems, aviation systems, medical equipment, amusement machines, vehicles, safety equipment, and installations subject to separate industry or government regulations.
- Systems, machines, and equipment that could present a risk to life or property.

Please know and observe all prohibitions of use applicable to the products.

NEVER USE THE PRODUCTS FOR AN APPLICATION INVOLVING SERIOUS RISK TO LIFE OR PROPERTY WITHOUT ENSURING THAT THE SYSTEM AS A WHOLE HAS BEEN DESIGNED TO ADDRESS THE RISKS, AND THAT THE OMRON PRODUCTS ARE PROPERLY RATED AND INSTALLED FOR THE INTENDED USE WITHIN THE OVERALL EQUIPMENT OR SYSTEM.

### PROGRAMMABLE PRODUCTS

OMRON shall not be responsible for the user's programming of a programmable product, or any consequence thereof.

## Disclaimers

### CHANGE IN SPECIFICATIONS

Product specifications and accessories may be changed at any time based on improvements and other reasons.

It is our practice to change model numbers when published ratings or features are changed, or when significant construction changes are made. However, some specifications of the products may be changed without any notice. When in doubt, special model numbers may be assigned to fix or establish key specifications for your application on your request. Please consult with your OMRON representative at any time to confirm actual specifications of purchased products.

### DIMENSIONS AND WEIGHTS

Dimensions and weights are nominal and are not to be used for manufacturing purposes, even when tolerances are shown.

### PERFORMANCE DATA

Performance data given in this catalog is provided as a guide for the user in determining suitability and does not constitute a warranty. It may represent the result of OMRON's test conditions, and the users must correlate it to actual application requirements. Actual performance is subject to the OMRON Warranty and Limitations of Liability.

### ERRORS AND OMISSIONS

The information in this document has been carefully checked and is believed to be accurate; however, no responsibility is assumed for clerical, typographical, or proofreading errors, or omissions.

2009.12

In the interest of product improvement, specifications are subject to change without notice.

**OMRON Corporation**  
Industrial Automation Company

<http://www.ia.omron.com/>

(c)Copyright OMRON Corporation 2009 All Right Reserved.